

IRIS-S435



QUICK-START GUIDE

Regulatory Information

Disposal of Waste Equipment by Users in Private Household in the European Union.



This symbol on the product or its packaging indicates that it must not be disposed of with your other household waste. Instead, it is your responsibility to dispose of your waste equipment by handing it over to a designated collection point for the recycling of waste electrical and electronic equipment. The separate collection and recycling of your waste equipment at the time of disposal will help to conserve natural resources and ensure that it is recycled in a manner that protects human health and the environment. For more information about where you can drop off your waste equipment for recycling please contact your local city office, your household waste disposal service or the shop where you purchased the product.



This device has been tested and found to comply with the limits for a Class B digital device, pursuant to Part 15 of the FCC rules. These limits are designed to provide reasonable protection against harmful interference in a residential installation. This equipment generates, uses and can radiate radio frequency energy and, if not installed and used in accordance with the instructions, may cause harmful interference to radio or television reception. However, there is no guarantee that interference will not occur in a particular installation. If this equipment does cause interference to radio and television reception, which can be determined by turning the equipment off and on, the user is encouraged to try to correct the interference by one or more of the following measures: Reorientate or relocate the receiving antenna; Increase the separation between the equipment and the receiver, connect the equipment to an outlet on a different circuit from that to which the receiver is connected; consult the dealer or an experienced radio / TV technician for help.



We hereby declare that the product is in compliance with the essential requirements and other relevant provisions of EMC Directive 2014/30/EC, the RoHS Directive 2011/65/EU.

IRIS435 User Guide

(C) 2025 Iris Innovations Limited.

ALL RIGHTS RESERVED

Any and all information, including, among others, wordings, pictures, graphs are the properties of IRIS INNOVATIONS., Ltd. or its subsidiaries (hereinafter referred to be “IRIS”). This user manual (hereinafter referred to be “the Manual”) cannot be reproduced, changed, translated, or distributed, partially or wholly, by any means, without the prior written permission of IRIS. Unless otherwise stipulated, IRIS does not make any warranties, guarantees or representations, express or implied, regarding to the Manual.

LEGAL DISCLAIMER

TO THE MAXIMUM EXTENT PERMITTED BY APPLICABLE LAW, THE PRODUCT DESCRIBED, WITH ITS HARDWARE, SOFTWARE AND FIRMWARE, IS PROVIDED “AS IS”, WITH ALL FAULTS AND ERRORS, AND IRIS MAKES NO WARRANTIES, EXPRESS OR IMPLIED, INCLUDING WITHOUT LIMITATION, MERCHANTABILITY, SATISFACTORY QUALITY, FITNESS FOR A PARTICULAR PURPOSE, AND NON-INFRINGEMENT OF THIRD PARTY. IN NO EVENT WILL IRIS, ITS DIRECTORS, OFFICERS, EMPLOYEES, OR AGENTS BE LIABLE TO YOU FOR ANY SPECIAL, CONSEQUENTIAL, INCIDENTAL, OR INDIRECT DAMAGES, INCLUDING, AMONG OTHERS, DAMAGES FOR LOSS OF BUSINESS PROFITS, BUSINESS INTERRUPTION, OR LOSS OF DATA OR DOCUMENTATION, IN CONNECTION WITH THE USE OF THIS PRODUCT, EVEN IF IRIS HAS BEEN ADVISED OF THE POSSIBILITY OF SUCH DAMAGES.

REGARDING TO THE PRODUCT WITH INTERNET ACCESS, THE USE OF PRODUCT SHALL BE WHOLLY AT YOUR OWN RISKS. IRIS SHALL NOT TAKE ANY RESPONSIBILITIES FOR ABNORMAL OPERATION, PRIVACY LEAKAGE OR OTHER DAMAGES RESULTING FROM CYBER ATTACK, HACKER ATTACK, VIRUS INSPECTION, OR OTHER INTERNET SECURITY RISKS; HOWEVER, IRIS WILL PROVIDE TIMELY TECHNICAL SUPPORT IF REQUIRED.

SURVEILLANCE LAWS VARY BY JURISDICTION. PLEASE CHECK ALL RELEVANT LAWS IN YOUR JURISDICTION BEFORE USING THIS PRODUCT IN ORDER TO ENSURE THAT YOUR USE CONFORMS THE APPLICABLE LAW. IRIS SHALL NOT BE LIABLE IN THE EVENT THAT THIS PRODUCT IS USED WITH ILLEGITIMATE PURPOSES.

IN THE EVENT OF ANY CONFLICTS BETWEEN THIS MANUAL AND THE APPLICABLE LAW, THE LATER PREVAILS.

Warnings & Important Product Information

WARNING: Installation and Operation

This product must be installed and operated in accordance with these instructions. Failure to do so may result in poor product performance, damage to the product or vessel and or personal injury. Installation should only be carried out by qualified personnel or by persons competent in electrical systems.

WARNING: Power Supply and Grounding

Ensure the boats power supply is switched off during installation. Ensure suitable rated circuit breakers / fuses are used in the installation of the product in accordance with the electrical values shown in the technical specifications of the product. Never switch on power until the power connections are correctly terminated in accordance with the information provided in this document. Do not connect or disconnect the product with the power supply switched on. Never disconnect the DC ground with the power supply on.

WARNING: Wiring terminations

Where the products video, power and data terminations are extended, ensure that suitable connectors are used and that the point of termination for each cable is adequately protected against moisture ingress. Ensure correct polarity is strictly observed. Do not cut or remove cable connectors without prior permission from Iris Innovations Limited.

WARNING: Do Not Open the Unit

There are no user serviceable parts within the product so there is no need to open the device. The product has been certified to IP66 standards, however, submersion or the product or exposure to high pressure washing will invalidate the warranty.

WARNING: Disclaimer

This product is intended to be used only as an aid to navigation and must never be used as an alternative to correct navigational practices and judgements made on the basis of approved navigation methods. It is the users responsibility to observe correct and proper navigational skill when using this product. Only officially approved charts and notices to mariners contain the current information required for safe navigation.

Operating the camera or viewing the video input whilst the vessel is moving could cause a distraction and result in accidental collision resulting in property damage, injury or death. Iris Innovations cannot be held liable for any incidental, special, indirect or consequential damages whether resulting from the use, misuse or inability to use this product.

CAUTION: Switch Camera Off When Not in Use.

To prolong the operation life of the the cameras sensor we strongly advise that power to the camera is routed via a dedicated switch.

CAUTION: Service and Maintenance

This product contains no user serviceable parts. Please refer all maintenance and repair issues to your authorised Iris Innovations dealer. Any unauthorised work to the product may affect the warranty.

CAUTION: Care and Cleaning

This product is a sensitive piece of electronic, imaging equipment and must be handled and treated accordingly. Do not drop or shake the unit during installation. Avoid exposure of the imager to direct sunlight where possible as this may degrade the cameras performance over time.

When cleaning the device, ensure power is switched off. Clean the camera housing with a soft cloth. Moisten the cloth and use a mild detergent if required. The lens window has a protective coating which may suffer damage as a result of improper cleaning. To clean the lens window use a soft cotton cloth. Moisten with clean water if necessary. For further advise on cleaning the lens window, contact Iris Innovations.

INFORMATION: Product Disposal and Recycling

Dispose of this product in accordance with the WEEE Directive. The Waste Electrical and Electronic Equipment (WEEE) Directive requires the recycling of waste electronic and electrical equipment. Iris Innovations supports the WEEE policy and politely request you observe correct disposal methods. For further information on how to correctly dispose of this product please contact Iris Innovations.

Please recycle unwanted packaging and documentation. The cardboard carton, all paper manuals and documents and the protective plastic bag in which the camera is shipped are widely recyclable. Please check with your local recycling plant for confirmation.

EMC Guidelines

This camera is designed to be used as a visual aid and is not part of the vessels navigational system - even if used in conjunction with other on board equipment or third party systems - and is compliant with the EMC directive 2014/30/EC. The original Declaration of Conformity (DoC) is available from our website

The camera should not be installed on the ships helm or in close proximity to radio receiver equipment. We recommend the camera is installed no closer than 1m from any equipment transmitting or cables carrying radio signals - particularly VHF radios and associated equipment.

The camera should be powered from a clean 12VDC supply or suitable IEEE802.3af PoE supply. If any interference occurs on either the camera or nearby equipment, the effected equipment should be separated by a greater distance.

Water Ingress: Disclaimer

This product has been tested and complies with the requirements of the standard EN60529 to level IP66, however, water intrusion and subsequent equipment failure may occur is subject to commercial high pressure washing or sustained exposure to water spray. This product is not designed to be submerged. Any damage caused as a result of these circumstances are not covered by the product warranty.

NOTE:

Due to manufacturing techniques there may be minor variations in the form of the stainless steel cowling. This is expected and does not detract from the performance and overall aesthetic of the product.

Introduction

Thanks for buying the IRIS-S435 Multi Purpose Through-Panel Mounting Submersible Hi-Def Bullet Camera from Iris Innovations.

Boasting rugged, corrosion proof 316L marine grade stainless steel construction, IP68 submersible case, 3MP Hi-Def resolution and inbuilt LED illumination, the S435 camera can be used for multi applications both above and below the waterline, for security, safety and situational awareness.

The IRIS-S435 is an ONVIF compliant device which means it can be viewed on any ONVIF hardware, including DVR's, computers and compatible MFD's such as Raymarine's Axiom, Navico devices such as Simrad NSS range, Furuno TZT3 Timezero and other network plotters. For compatibility information please contact your Iris dealer or visit www.boat-cameras.com

Overview of Key Features

Here's a brief list of some of the IRIS460's key features:

- Up to 3MP Resolution (2304 x 1296)
- High Performance LED's - 10 Meter Range
- Mechanical IR Cutout filter for True Day / Night Operation
- Low Power 12VDC Operation <150mA
- IEEE802.3af Power over Ethernet (PoE)
- Various Lens Options (3.6mm / 2.8mm / 1.8mm)
- IP66 Ingress Protection
- Small, Compact Housing
- Marine Grade 316 Stainless Steel Housing (IRIS-S460 models)
- Suitable for Multiple Applications, such as on-board security, sports fishing, engine room monitoring and vehicle monitoring
- Wide Operating Temperature Range
- Compatible with ONVIF compliant Chart Plotters such as the Raymarine Axiom and all other Raymarine network MFD's running Lighthouse II & III software, Furuno Timezero 4.1 Software (PC version), Navico NEON, NOS operating systems.

Contents of Package

Please unpack your IRIS460 and check to make sure the following items are included. If there are any items missing please contact your Iris dealer:

- 1 x IRIS435 Marine Mini Dome Camera
- 1 x Fixing Pack
- 1 x Instruction Manual
- 1 x Water Resistant RJ45 connector kit
- 2 x Angle Fitting Wedges
- 1 x Locking Ring

Camera Overview

The diagram below details the various parts of your camera:

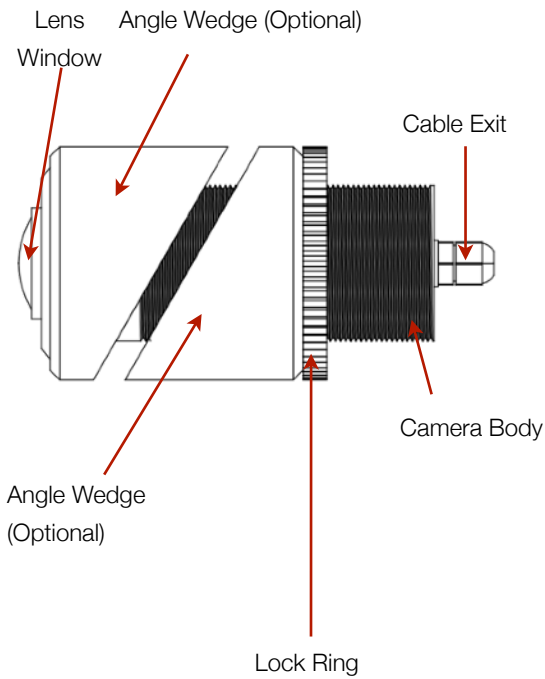

The camera is supplied with two stainless steel angled wedge mounts which can be used to adjust the mounting angle.

When using the wedge mounts, locate one mount either side of the mounting surface and lock in place by tightening the lock ring

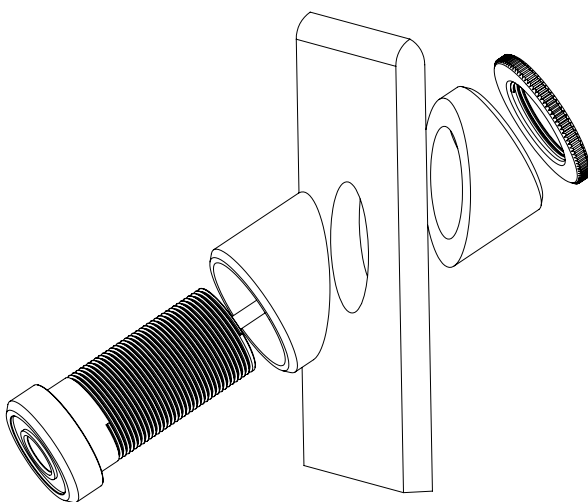

Installing IRIS-S435 with Angle Wedges

Installation

WARNING!

Only trained electrical installers or competent persons should install this product. Incorrect installation could lead to personal injury or death and/or damage to property. Ensure the electrical regulations specific to your region are observed, and observed wiring colour conventions.

Ensure the cameras power supply is connected via a suitably rated fuse or circuit breaker.

Switch off the power supply you are working on whilst installing the camera, until the product is correctly installed.

It is strongly advised that the camera is powered up and connected to a monitor / computer to check the desired field of view prior to fixing the camera in place.

Iris do not accept any liability if the camera is installed and does not cover desired field of view.

We recommend using our IRIS996 camera test unit for this process .The IRIS996 is compatible with IP and Analogue Hi-Def cameras, can record video and can also power external devices via 12VDC or PoE.

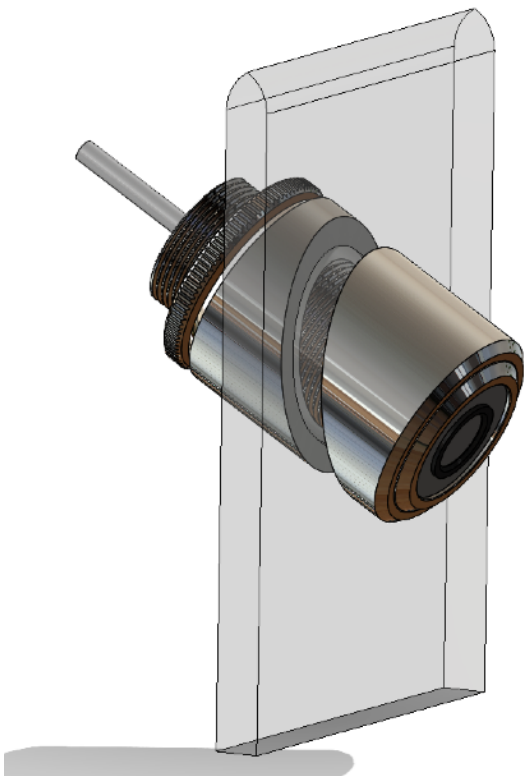

Step 1.

Established desired mounting position.

Step 2.

Ensure there is sufficient space behind the surface to accommodate the camera body and cable exit.

Step 3.

Ensure there are no obstacles such as cables, pipes, conduits etc behind the drilling location.

Step 4.

Ensure you have access behind the panel to tighten the lock ring (and fit the angle wedge if being used).

Step 5.

Use an appropriately sized pilot drill in the centre of the desired drilling position.

Step 6.

Carefully open out the pilot hole using a 32mm hole saw - taking extreme care not to splinter GRP etc. If using the angle wedge, create the hole taking into account the angle through the surface at which the camera body will require. It may be necessary to carefully cut and adjust as necessary depending on the mounting surface. This should only be undertaken by a person proficient with the necessary installation and fitting practices.

Step 7.

If using angle wedge, fit one piece to the camera, adjust camera orientation as required, and feed through panel, then slide the other angle wedge to create a flat face onto which the lock ring can tighten.

Step 8.

Lock firmly into place with the rock ring.

Step 9.

Apply power to test orientation.

Step 10.

Use an appropriate marine grade sealant where necessary to prevent moisture ingress behind cut panel.

How to fit Field Installable Waterproof RJ45 Jacket

When installing in an external location, or any position that will be prone to moisture ingress or harsh weather, it is important the the waterproof RJ45 connector (supplied) is used to protect the cameras connections.

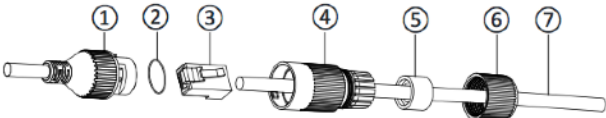

Part No	Description
1	Cameras Network Interface Socket
2	O Seal
3	RJ45 Network Connector
4	Waterproof Endcap
5	Rubber Gasket
6	Lock Nut
7	Network cable to Router / Switch / Hub / etc..

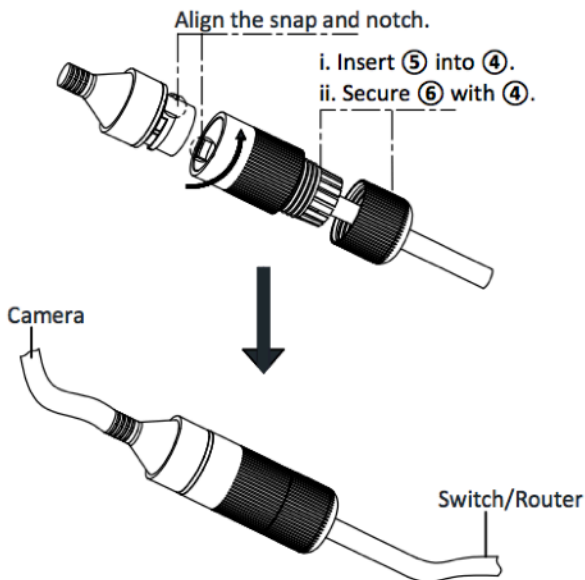

Method

Step.1:

Feed the plug-less network cable (7) through the lock nut (6), waterproof rubber gasket (5) (ensuring the rubber gasket inset ridge faces the end-cap (4)).

Step.2:

Crimp an RJ45 Network plug (3) onto the end of the cable in accordance with the diagram below, taking care to ensure the wires are terminated in the correct order and are not crossed.

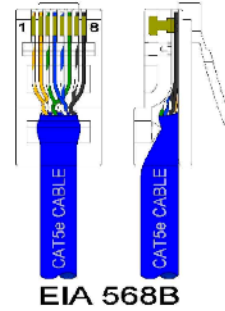

Pin No	Wire Colour
1	White / Orange
2	Orange
3	White / Green
4	Blue
5	White / Blue
6	Green
7	White / Brown
8	Brown

Step.3:

Place the O Seal (2) onto the end of the cameras network interface socket (1).

Step.4:

Insert the network plug (3) into the cameras network interface socket (1).

Step.5:

Insert the waterproof rubber gasket (5) into the waterproof end-cap (4) and secure lock nut (6) with the waterproof end cap (4).

Step.6:

Align the snap on waterproof end-cap (4) with the notch on the cameras network interface socket (1) and then secure the waterproof end-cap (4) to the cameras network interface socket (1).

Configuring the Camera over the LAN

WARNING: Stay Secure!

When connecting any device to a network with access over the internet brings risks to the security of your network and your data. Your IRIS-S435 features built in User Name and Password authentication but it is also your responsibility to strengthen your network security where ever possible. Please contact your IT expert for further advise. Iris cannot provide support with any aspect of your network security, other than the cameras built in security settings.

Basic Setup: Single Camera / Computer

The diagram below shows a very basic setup, with a single camera being viewed on a PC (or laptop).

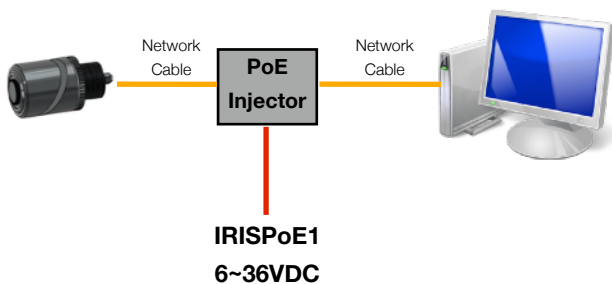

Use a standard 568B ethernet CAT5 cable to hook your computer up to the PoE injector, and then another 568B cable to hook the camera up to the injector.

With this type of installation, you must ensure the IP address of the camera is in the same range as the network adapter in your computer used to communicate with the camera. Consult documentation for your computer for information on how to view (and edit) your network adapter IP address.

The camera is set as default to DHCP, which means it has no IP address set, and awaits for a router on your network to assign the address.

To find your camera on the network, use an IP camera discovery tool, or an ONVIF Device Manager.

A great Onvif Device Manager can be found here: <https://sourceforge.net/projects/onvifdm/>

Once you've downloaded and installed the Device Manager software, open the program and then click the REFRESH button at the bottom of the device list on the left hand side. If everything is hooked up correctly, the details of your camera, including its IP address, will be displayed in the list.

If the cameras IP address falls outside the range of the IP address of your computers network adapter, you'll have to change the address on your adapter so it corresponds with the address of the camera. Once this is done (and you'll usually need to reboot your computer) you should simply be able to open your web browser, type the IP address of the camera into the address bar and access the camera. From here, if required, you can change the IP address of the camera as desired - back to the original address range of your computer for example. If you do this, then you will also have to change the address of your network adapter back to its previous range.

Basic Setup: Single Camera / Computer via Router using DHCP (default)

The diagram below shows a simple one camera / one computer device, but this time a router is used to manage your network devices and address allocation.

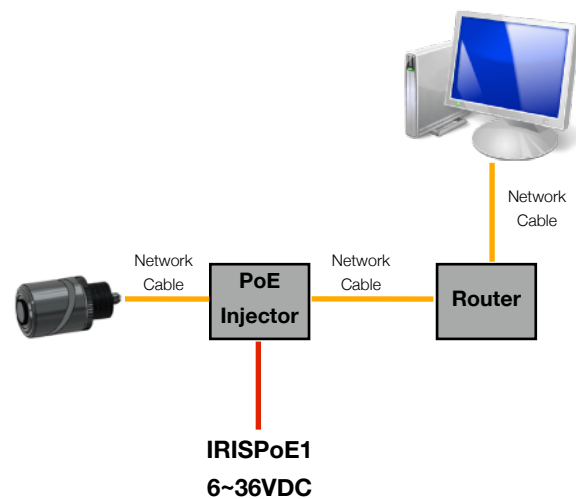

As mentioned previously, the camera as default is set to obtain its IP address automatically via DHCP. This means that once connected, your router will detect the device and assign it an IP address within its designated range (refer to the documentation for your router for further details). You must also ensure the network adapter for your computer is set to obtain its address via DHCP.

Operation

IP Addressing & DHCP (Dynamic Host Control Protocol).

Devices on your network require their own, unique IP address. Your camera is factory set as DHCP (Dynamic Host Control Protocol).

DHCP Addressing

DHCP allows devices on the network to receive their IP address automatically from a server (or a device on the network that acts as a server - such as a Raymarine MFD).

Nowadays, pretty much all routers have a DHCP server feature, which usually just needs enabling and configuring. Care should be taken on larger networks to ensure there are no conflicts if multiple routers or devices are configured as DHCP servers. Please refer to your IT specialist for further details if you are unsure.

Raymarine MFD's

For Raymarine MFD's, including Axiom models, running Lighthouse 2 or higher, all you need to do is connect the camera to your Raymarine network and wait! Your Raymarine device will take a few minutes to assign the camera address at first, but once assigned, your camera should appear within a short while after the MFD boots up and initializes.

NOTE: The first time you hook your camera up to the Raymarine it may take some time for the MFD to discover the camera. This is normal.

Static (or Fixed) IP Addressing

If you are not using a DHCP server, you will need to log onto the camera and assign an address to fit in with your network address range. This sounds obvious, and like it should be a basic step, but can actually be a major challenge, as you can only log into the camera if its address is in the same range as your network. If you do not have experience in this field we recommend you consult your IT specialist, as making undesirable changes to your settings could result in major network problems. For further details, please contact your Iris dealer.

Discovering your Camera

To discover your camera on your network you can check your router for attached devices (if using DHCP) or use a software discovery tool, or an ONVIF device manager.

A great Onvif Device Manager can be downloaded from here: <https://sourceforge.net/projects/onvifdm/>

Remember, you'll only be able to find a device on your network if it's in the same IP address range. If you are unsure how to do this, consult your IT specialist.

Once you have found, or set your cameras address, you can log on to set up and view your camera.

Logging Into your Camera

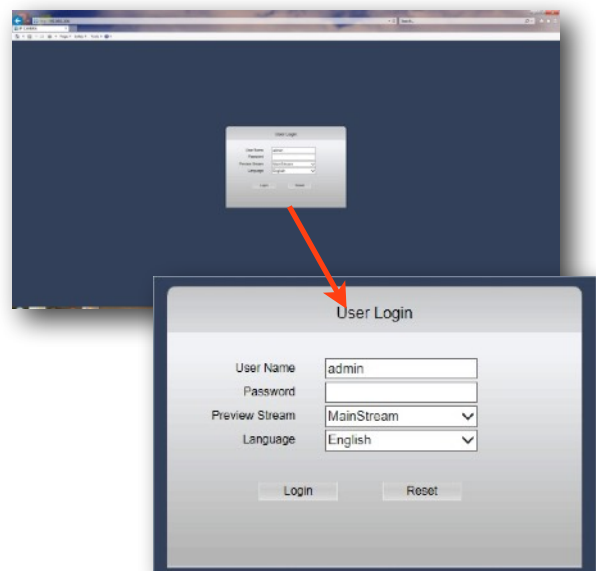

From your browser, type in your cameras IP address. The login page from the camera will be loaded up (see above).

The default log in details are as follows:

USER NAME: admin

PASSWORD:

No password is set as default.

Once you've entered the correct user-name and password the main window will be displayed. You can change the default user name and password from the cameras Set Up window.

Main Window

Playback
Used to search for stored snap-shots and videos as defined in Local Settings.

Local Settings
Defines path on local PC for storing snap-shots and video

Live View
Displays the live view from the camera

Remote Settings
Accesses Camera, Network and System Setting pages.

Logout
Logs out of the cameras interface.

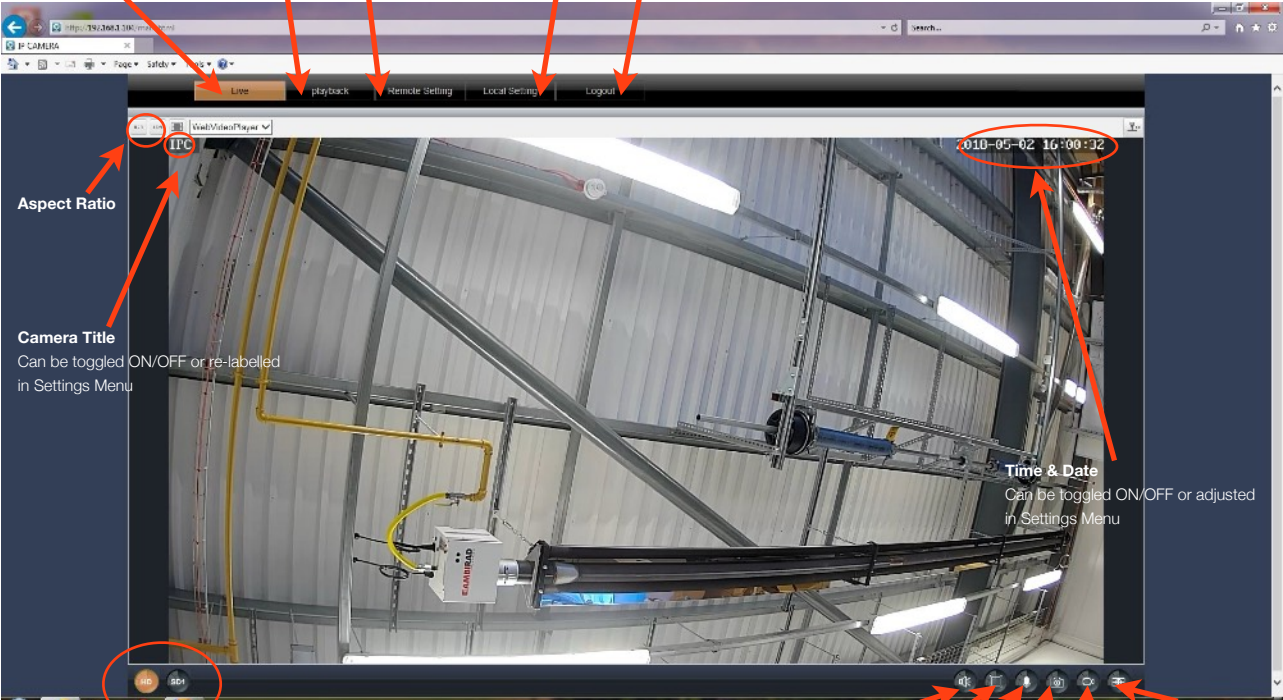

Aspect Ratio
Can be toggled ON/OFF or re-labelled in Settings Menu

Camera Title
Can be toggled ON/OFF or re-labelled in Settings Menu

Time & Date
Can be toggled ON/OFF or adjusted in Settings Menu

Video Definition
Toggle between Standard Definition (1280x720) or High Definition (1920 x 1080)

Volume
Not Enabled on IRIS460

Full Screen
Scales Live Video Panel to Full Screen

Microphone
Not Enabled on IRIS460

Snapshot
Stores snap shot to path defined in Local Settings

Video
Stores video to path defined in Local Settings

Zoom
Once enabled, allows user to draw 'Region of Interest' which will fill the screen

Playback Window

Snap-Shots and Videos from the IRIS435 can be stored on a local network device, such as a PC. To define the storage path, format and duration, use the **LOCAL SETTINGS** panel (see below).

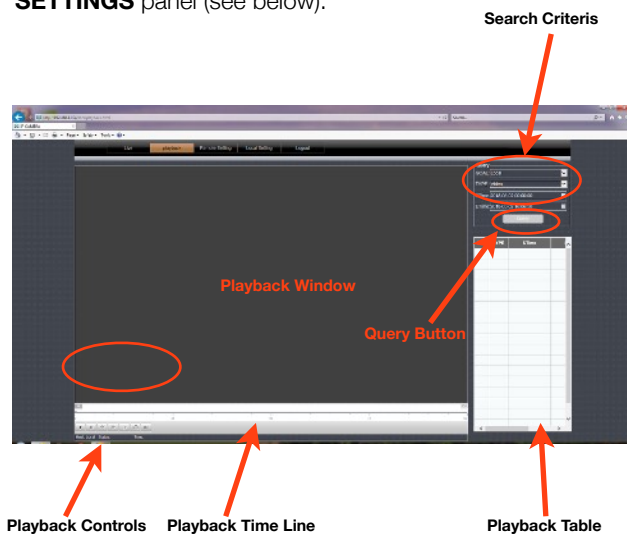

To search for files, set your desired start time (STime) and end time (ETime) and hit QUERY.

The list of available events will be displayed in the playback table.

To view an event, double click on the desired entry in the playback table.

Local Settings Window

Defines paths for storing Snap-Shots and Videos as detailed above.

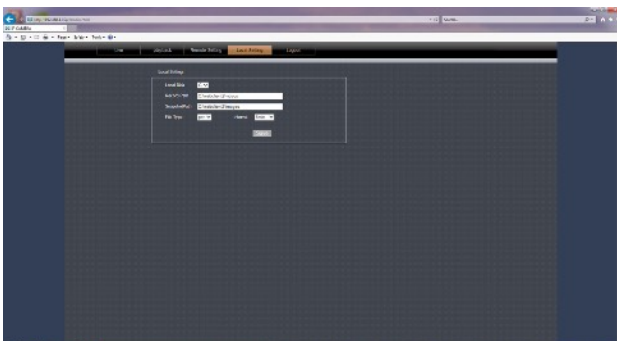

Remote Setting Window

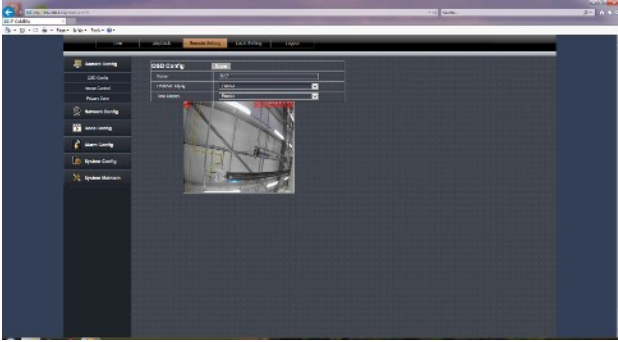

The Remote Settings window contains the following sub-menus:

Camera Config

OSD Config: Sets camera name and Time / Data display (shown in image below).

Image Ctrl: Sets image values (Brightness, Colour, Contrast etc, as well as IR settings (see below).

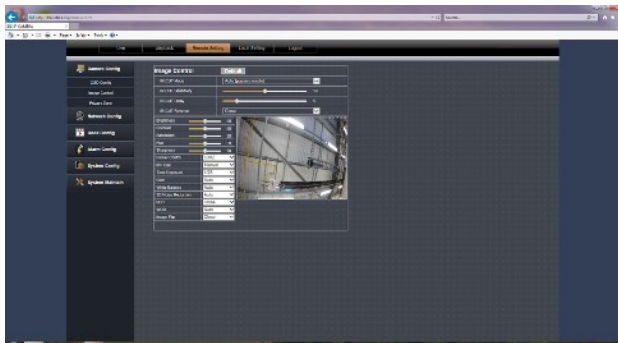

Privacy Zone: Configure multiple 'Privacy Zones' to black out areas that may either infringe privacy or you don't want other people with access to the camera to see.

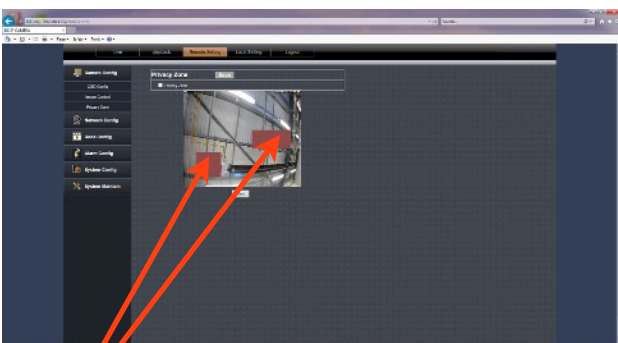

Use mouse (or touch-screen) to 'draw' privacy zones.

Network Config

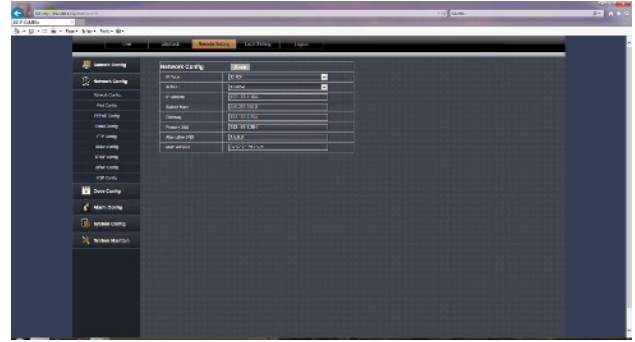

The Network Config tab contains the following sub menus:

Network Config: Set IP address details, including DHCP/ Static (shown above).

Port Config: Define network port settings (shown below).

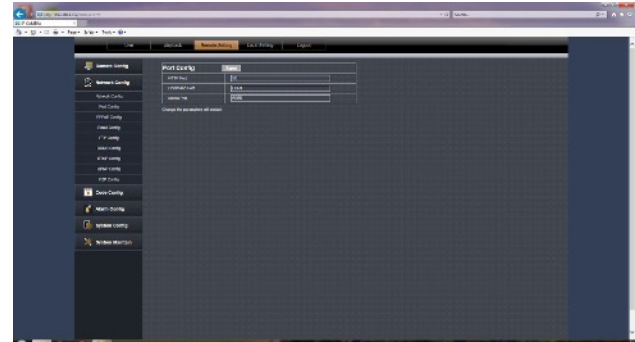

PPPoE Config: Enable / Disable PPPoE (default = disabled).

Email Config: Define email address snap-shots are sent to when an alarm (motion) is triggered. This requires an email account and the SMTP server details to configure.

FTP Config: Configure FTP server details for remote storage.

DDNS Config: Configure settings if you are using a Dynamic Domain Name Server.

RTSP Config: Configure RTSP port details. RTSP stream details are as follows:

MAIN Stream: rtsp://IP:Port/live/0/MAIN

SUB Stream: rtsp://IP:Port/live/0/SUB

Network Config (continued...)

UPnP Config: Configure UPnP protocol settings.

P2P Config: Configures Peer to Peer connections. Also displays QR Codes to download a generic F.O.C IP camera viewer App and the unique configuration to enable the camera to connect to a third party VPN host for remote viewing, which can be accessed from the App (see below).



Code Config

The code config window is where camera resolution, refresh rate, bit rate control etc are set. Both streams can be configured independently.

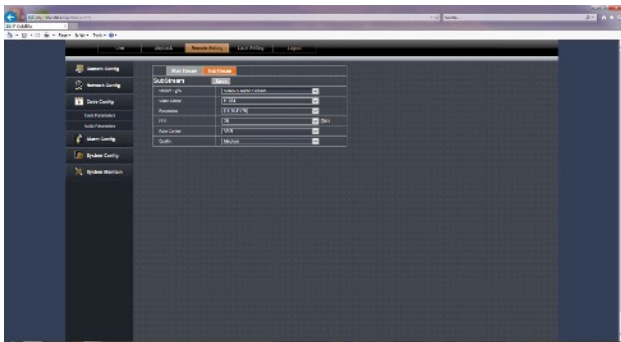

Alarm Config

The IRIS460 supports motion recording and scheduled recording.

For Motion Detection, you define the areas of the screen you wish to become 'alarmed' by drawing boxes as desired in the Alarm/Motion window. Subsequently, when motion is detected within these boxes, the camera enters alarm state and begins recording to the path defined in LOCAL SETTINGS.

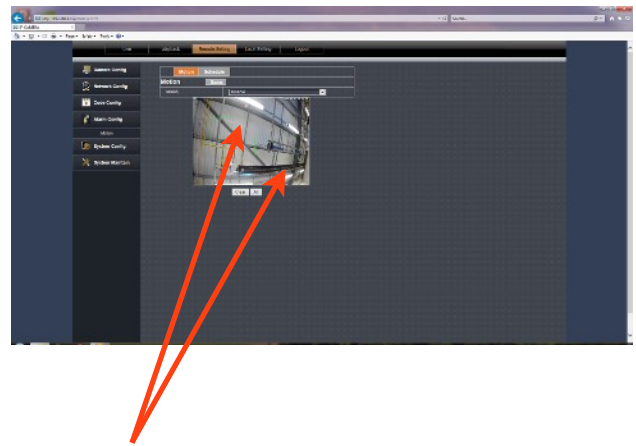

Use mouse (or touch-screen) to 'draw' motion alarm zones.

Scheduled Recording lets you define at which time and on which days the camera records, as shown below.

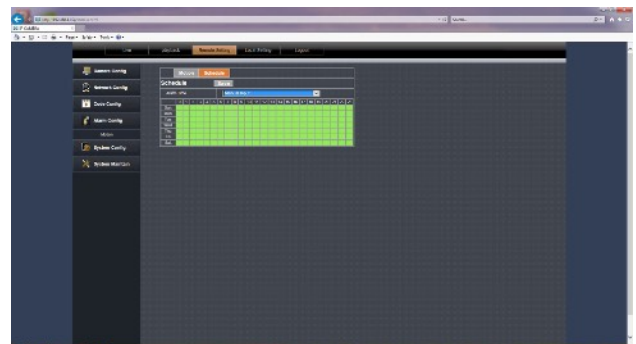

Iris Innovations

System Config:

The System Config window contains the following sub menus:

TIME SETTINGS:

Configure time zone settings and set Daylight Saving parameters

USER MANAGEMENT

Sets user accounts and privileges

DEVICE INFO

Displays camera serial number / software versions etc

LOG QUERY

Query camera error and activity log by time and date.

AUTO REBOOT

Specify a time you wish the camera to automatically reset

PTZ SETTINGS

Not Applicable

System Maintenance:

The System Maintenance menu has two sub menus:

FIRMWARE UPDATE:

Define the path new firmware is located to perform a firmware upgrade

RESTORE DEFAULT:

Restores the camera to its default settings.

Appendix:

Connectivity Issues: The IRIS-S435 camera is usually viewed via an MFD using the RTSP feed and as the camera is set to DHCP as default, usually (and depending on the model of MFD used) connection should be plug and play.

There will however be certain situations where you may want to view on a PC (computer based navigation system for example, during manual configuration or when viewing the camera remotely).

In this scenario, please ensure you use a compatible browser. Please check the up to date specifications on our website (www.boat-cameras.com) to check compatible browsers.

Please also ensure your PC's firewalls and Active X settings are configured correctly.

For Active X settings, navigate to the appropriate point in your browser security settings and allow all Active X connections. Failure to do so may result in the camera video not displaying correctly, even though the interface may load correctly.

The camera acts as a 'web server' and certain files may need to be automatically installed by your computer from the camera. Ensure your security settings allow files to be downloaded and installed from the camera.



Iris Innovations Limited

Unit 240 Ordnance Business Park
Aerodrome Road
Gosport
Hampshire PO13 0FG
United Kingdom

Tel: +44(0)2392 556509 / email: info@boat-cameras.com

www.boat-cameras.com