



Key Features:

- Panel Mount Waterproof Case
- Stylish Black Hard Anodised Finish
- Dynamic Menu System for Function Access
- Responsive 2 Axis Proportional Speed Thumbstick
- Supports Up To 6 Cameras and 18 Monitors
- Pelco D and Pelco D (Iris Variant) Protocols
- RS485 Serial Data
- Wide Operating Voltage - 6~36VDC
- Clear Backlit LCD Screen
- Easy, Intuitive Menu System for Feature Access

Applications:

- Work Boat & Commercial Shipping
- Luxury Motor Yachts
- Fishing & Sports Fishing
- Ferry Boats & Passenger Vessels
- Law Enforcement & Emergency Services
- Rapid Deployment Applications
- Vehicle & Transport Applications

Control up to 16 on board PTZ and Thermal cameras with the stylish IRIS595 panel mount joystick.

Featuring a responsive 2 axis proportional speed thumbstick and 8 feature buttons, the IRIS595 can drive Iris's complete range of PTZ and Thermal cameras and also interface with our hybrid video recorder range and matrix switchers to select 16 cameras to 16 monitors.

The IRIS595 is very easy to install, with 2 wires for DC power and 2 wires for RS485 serial data and transmits Pelco D protocol and Iris Variant data. High end power circuitry means the device can operate between 6~36VDC and also features reverse voltage protection.

The 8 feature buttons navigate through the devices dynamic intuitive menu system to access all the extended features built into Iris PTZ and Thermal PTZ cameras.

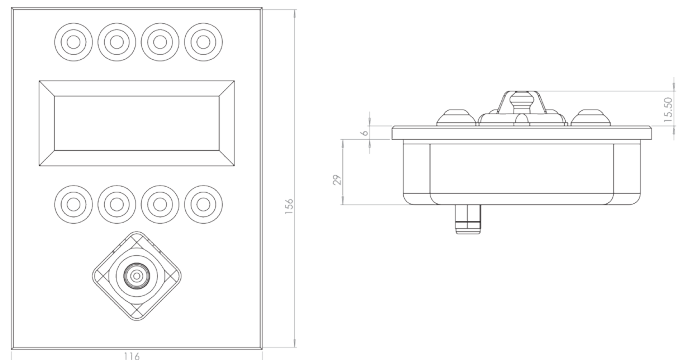

IRIS595	Specification
Weight & Dimensions	Analogue
Material	Aluminium, Hard Anodised / Matte Black Finish
Data / Protocol	RS485 Serial Data / Pelco D - Iris Variant
Control Interface	2 Axis Proportional Control thumbstick / 8 Dynamic Buttons
Power	8~36 VDC / <300mA @ 12VDC
Environmental	EN60529 / IP66