

595

IRIS595 Installation Manual



1.01 Conventions:

At various points within this guide, the following icons will be used to illustrate important or potentially dangerous information:



WARNING

This symbol indicates a risk of damaging the camera or other items or an important issue that may effect the operation of the camera.



INFORMATION

This symbol points out important information pertaining to the installation, operation and maintenance of the camera.



DANGER

This symbols alerts the user of a serious risk of damage or personal injury or death.

1.02 Limited Warranty:

This product is warranted to be free from defects in materials or workmanship for one year from the date of purchase. Upon registration of the product an additional 12 months warranty will be awarded FOC. Within this period, Iris Innovations will, at its sole option, repair or replace any components that fail in normal use. Such repairs or replacement will be made at no charge to the customer for parts or labour, provided that the customer shall be responsible for any transportation cost. This warranty does not apply to: (i) cosmetic damage, such as scratches, nicks and dents; (ii) consumable parts, such as batteries, unless product damage has occurred due to a defect in materials or workmanship; (iii) damage caused by accident, abuse, misuse, water, flood, fire, or other acts of nature or external causes; (iv) damage caused by service performed by anyone who is not an authorized service provider of Iris Innovations Limited or Iris Innovations USA Corporation; or (v) damage to a product that has been modified or altered without the written permission of Iris Innovations. In addition, Iris reserves the right to refuse warranty claims against products or services that are obtained and/or used in contravention of the laws of any country. This product is intended to be used only as a travel aid and must not be used for any purpose requiring precise measurement of direction, distance, location or topography.



2.01 Warnings & Important Product Information

WARNING: Installation and Operation

This product must be installed and operated in accordance with these instructions. Failure to do so may result in poor product performance, damage to the product or vessel and or personal injury. Installation should only be carried out by qualified personnel or by persons competent in electrical systems.

WARNING: Power Supply and Grounding

Ensure the boats power supply is switched off during installation. Ensure suitably rated circuit breakers / fuses are used in the installation of the product in accordance with the electrical values shown in the technical specifications of the product. Never switch on power until the power connections are correctly terminated in accordance with the information provided in this document. Do not connect or disconnect the product with the power supply switched on. Never disconnect the DC ground with the power supply on.



WARNING: Wiring terminations

Where the products, power and data terminations are extended, ensure that suitable connectors are used and that the point of termination for each cable is adequately protected against moisture ingress. Ensure correct polarity is strictly observed. Do not cut or remove cable connectors without prior permission from Iris Innovations Limited.



WARNING: Do Not Open the Unit

There are no user serviceable parts within the product so there's no need to open the device. The product has been certified to IP66 standards, however, submersion or the product or exposure to high pressure washing will invalidate the warranty.



WARNING: Disclaimer

This product is intended to be used only as an aid to navigation and must never be used as an alternative to correct navigational practices and judgments made on the basis of approved navigation methods. It is the users responsibility to observe correct and proper navigational skill when using this product. Only officially approved charts and notices to mariners contain the current information required for safe navigation.



Operating the device or viewing the video input whilst the vessel is moving could cause a distraction and result in accidental collision resulting in property damage, injury or death. Iris Innovations cannot be held liable for any incidental, special, indirect or consequential damages whether resulting from the use, misuse or inability to use this product.

CAUTION: Switch Controller Off When Not in Use.

To prolong the operation life of the thermal camera's microbolometer sensor we strongly advise that power to the camera is routed via a dedicated switch.



CAUTION: Service and Maintenance

This product contains no user serviceable parts. Please refer all maintenance and repair issues to your authorized Iris Innovations dealer. Any unauthorized work to the product may affect the warranty.



CAUTION: Care and Cleaning

This product is a sensitive piece of electronic, imaging equipment and must be handled and treated accordingly. Do not drop or shake the unit during installation. Never manually alter the pan or tilt position whilst the power to the unit is on as this may permanently damage the motors. Avoid exposure of the imager to direct sunlight where possible as this may degrade the cameras performance over time.

When cleaning the device, ensure power is switched off to avoid unintentional movement of the cameras motors. Clean the camera housing with a soft cloth. Moisten the cloth and use a mild detergent if required but take care not to get detergent on the lens window. The lens window has a protective coating which may suffer damage as a result of improper cleaning. To clean the lens window use a soft cotton cloth. Moisten with clean water if necessary. For further advise on cleaning the lens window, contact Iris Innovations.



3.01 Introduction

Thanks for buying the IRIS595 thermal imaging camera controller from Iris Innovations!

By choosing Iris Thermal Imaging you have added a highly sensitive imaging device to your boat that aids visibility during the day and perhaps more importantly, at night or in low light conditions, thus enhancing your on board safety and enjoyment.

The IRIS595 controller has been especially designed to control the pan, tilt and zoom functions and operate extended features of Iris thermal imaging cameras such as Nightrunner and IRIS390 models.

This document contains safety, handling, disposal and recycling regulatory and software license information as well as the one-year limited (and second year optional) warranty for your IRIS595 Controller. Please follow the information in this guide and keep in a safe place for future reference.

3.02 Overview of Key Features

Here's a brief list of some of the IRIS595's Key Features:

- Compact, Water Resistant Housing
- Intuitive Menu Driven operation
- Miniature 2 Axis for Pan and Tilt
- RS485 Serial Data Communications
- Supports Pelco-D Protocol
- Supports up to 16 Cameras
- Supports Iris Matrix Switching
- Supports 16 User Presets

4.01 Typical Configuration Examples.

For single camera, single controller installs no additional hardware is required. Simply connect the IRIS595 controller directly to the data lines of the breakout balun, and run the video from the breakout balun directly into your screen (or chartplotter etc).



If there are multiple cameras, controllers or other PTZ cameras on the system, it will become necessary to add a serial data distributor in order to balance the data and ensure there are no signal reflections that could result in over-runs and poor camera control. Below is an example of a system with 2 controllers and 4 cameras. An IRISEXP0204 data expander has been used to manage the data cables, and an IRIS604 Quad Video Switcher has been used to manage the four video feeds.

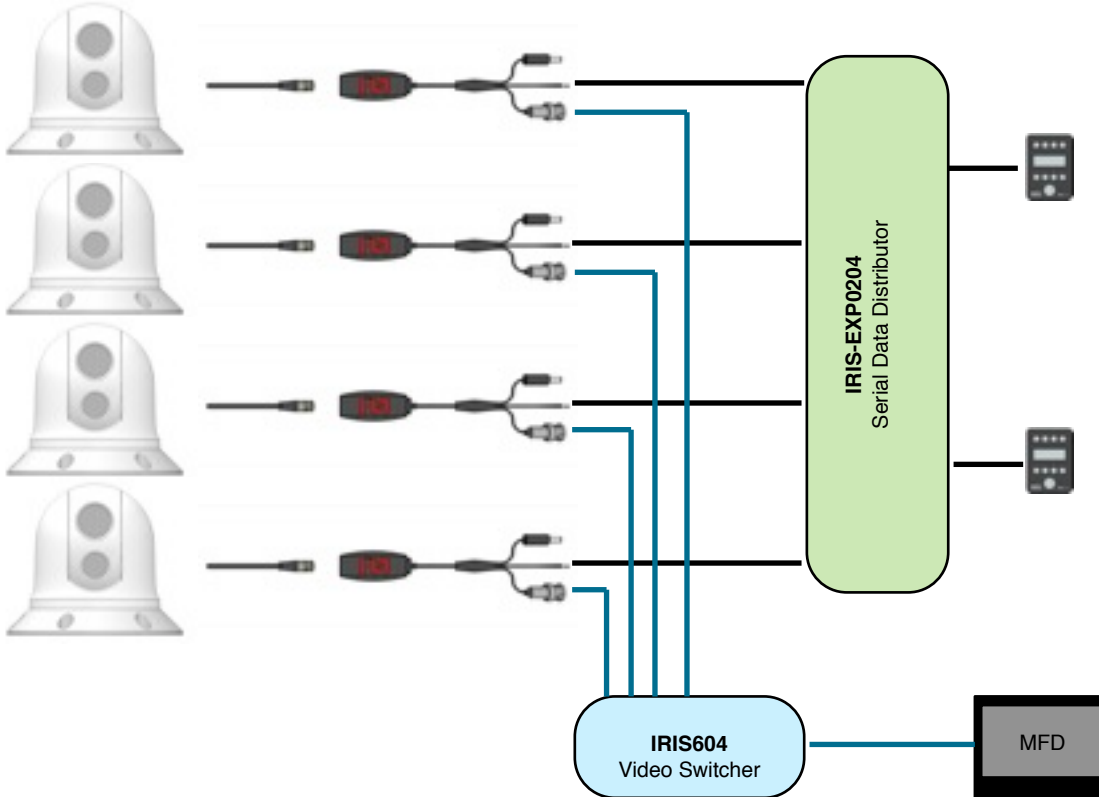

Systems can be expanded by using Serial Data Expanders to manage the control data and Video Distribution Amplifiers, Video Switchers or Matrices to manage multiple video feeds. In addition, IP encoders can be added to enable connection over a computer network so cameras can be viewed and controlled from smart-phones, tablets and computers. For further information or to discuss your requirements, please contact Iris.

5.01 Hardware Installation

The IRIS595 controller is designed to be panel mounted into a dashboard or helm. The cutting template is enclosed.

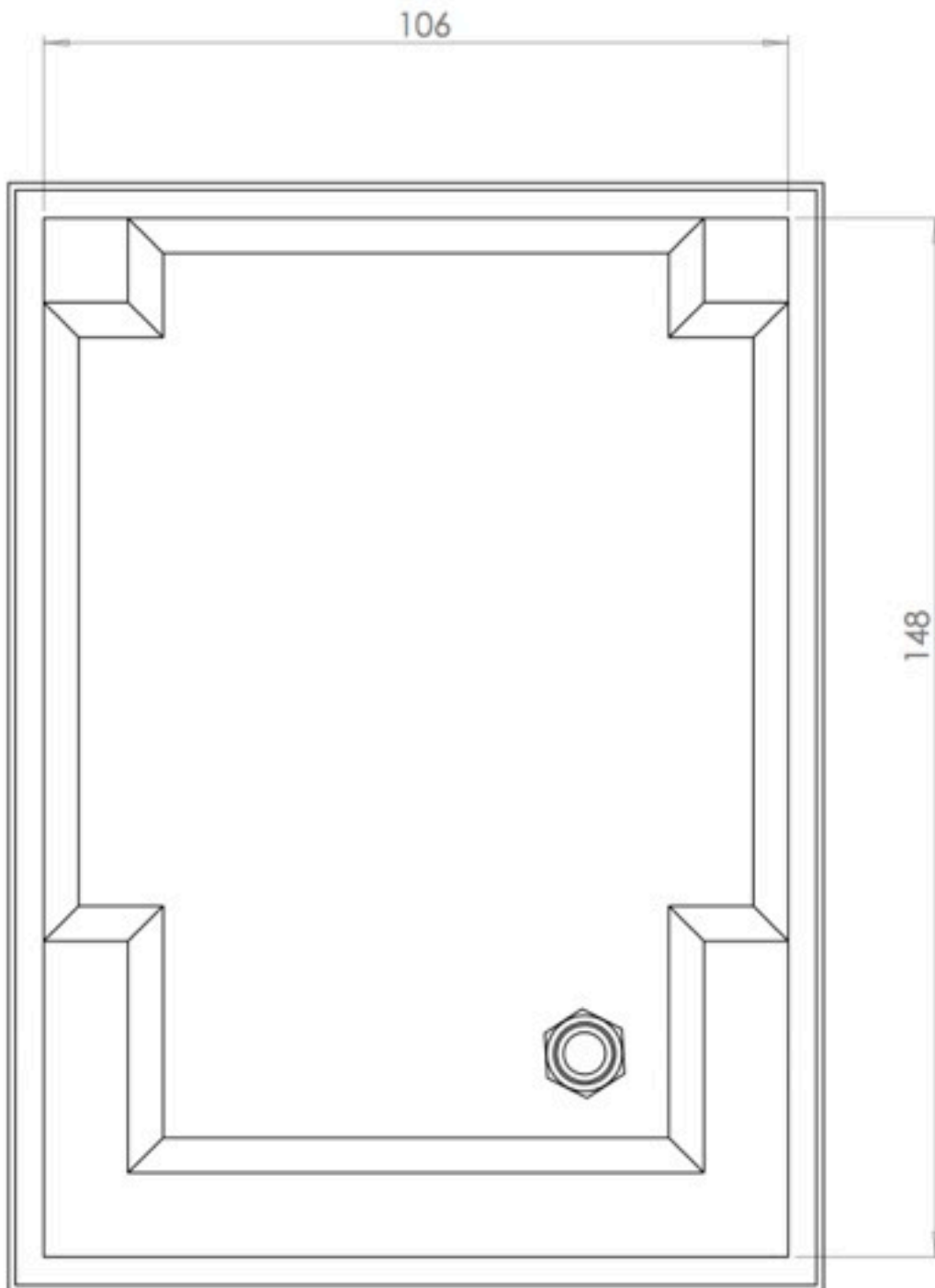

Fixing Points:

To fit the IRIS595 controller, offer up the template to the surface into which you intend to mount, securely fix the template and then cut to the dimensions shown on the template (shown above).
Apply a bead of suitable marine sealant around the underside of the bezel and then fit the controller into the cut-out.

6.01 Connecting Up

The fitted power and data cable is provided with bare ends to aid in installation, so please ensure that care is taken in identifying the relevant connections and polarity.

Data communications to cameras and other devices is achieved via a two wire RS485 connection, and the data connection pins on the controlled devices will be labelled appropriately with a "+" (positive) and a "-" (negative) indicator.

Combinations of multiple control devices and multiple cameras may be connected together using and Iris Data Expander.

Power your unit from a dedicated fuse / breaker rated at 12VDC / 500mA. The unit operates when power to the breaker / fuse is applied. Ensure suitably rated cable is used to handle the required current and voltage.

Connections from the cable:

Colour	Function
Red	12v DC power
Black	0V DC / Ground
Green	RS485 Data +
White	RS485 Data -

7.02 Powering Up

Never apply power to the device unless all connections are terminated correctly. Never disconnect the DC ground for any reason whilst the device is powered up as this could result in damage to the electronic circuitry.

Upon power-up, the controller will perform a brief initialization sequence that will take a few seconds. An animated NightRunner logo is displayed in the LCD screen during this period. After initialization the controller is ready to use.

8.01 Controlling the Camera - Overview

Your camera features positional controls and extended features. Positional features such as Pan and Tilt are operated by moving the thumb-stick, whereas Zoom, Camera Selection and other extended functions are controlled by pressing the button that corresponds to the specific feature displayed on the LCD screen.

9.01 Controlling the Camera - IRIS595

This section explains how the camera features are controlled and selected using the dedicated IRIS595 Joystick Controller.

Below is the IRIS595 HOME Screen:

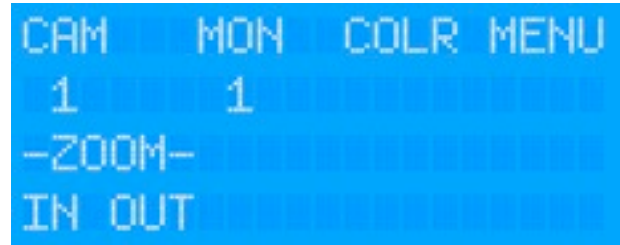

Camera Select

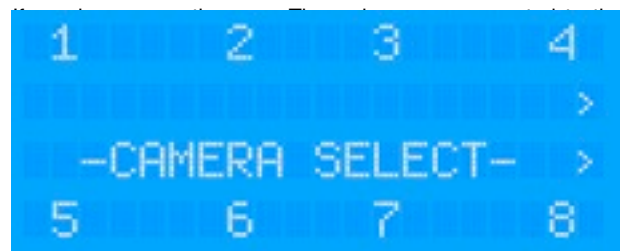

Select the desired camera (1~8) or move the joystick RIGHT to access cameras 9~16. Once the desired camera is selected the controller will return to the HOME screen.

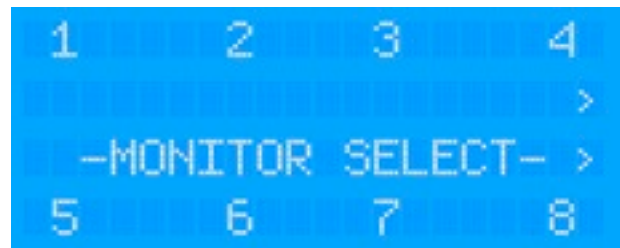

Select the desired monitor (1~8) or move the joystick RIGHT to access monitors 9~16. Once the desired monitor is selected the controller will return to the HOME screen.

Switching Between Thermal / Daylight Cameras

If a dual payload cameras such as an IRIS Nightrunner is connected, it is possible to switch between the two cameras using the IRIS595 controller by selecting either DAY for the daylight camera or NIGHT for the thermal imaging camera from the home screen.

Zoom Control

All IRIS PTZ cameras feature zoom functionality. From the home screen on the IRIS595 press IN to increase magnification and OUT to zoom wide.

9.01 Controlling the Camera (Continued...)

Colour

If you are using a Thermal camera which supports alternate thermal imaging colour palettes, they can be selected from this screen. Pressing the same button a second time will invert the palette.

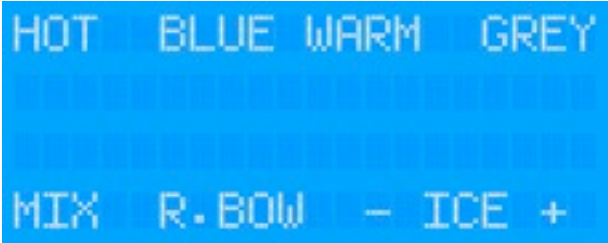

ICE

The ICE (Image Contrast Enhancement) feature, also specific to Nightrunner series cameras with palette support, high-lights details in scenes which may be otherwise missed.

The sensitivity of the ICE setting can be controlled using the “+” and “-“ buttons and set between 0 and 7, where 7 is the most sensitive and 0 is the least.

MENU

Extended features are accessed by pressing the MENU button. Please note, in certain menus, camera control functions are disabled. To exit back to the home screen at any time move the joystick up. The menu screen is shown below:

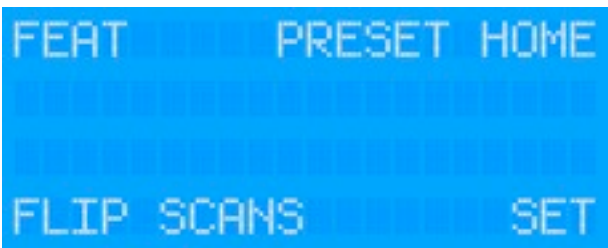

Image Flip

If you need to change the image orientation, select the FLIP option and you will be presented the screen below:



FLIP UP refers to the standard ‘desktop’ orientation. The MIRROR option will flip the image horizontally (useful when using the camera to look backwards). FLIP DOWN refers to the camera in the hanging orientation.

Please Note: Vertical FLIP Orientation can be permanently set via the DIP switches in the base of the camera. See Section: 10.02 for more details.

Home

The Home button will send the camera to it’s pre-programmed home position. Please see section 9.01 for more information on presets.

Scans

The camera supports 4 different Scan Modes. Once activated, tilt and zoom commands are still accepted by the camera but you will not be able to pan the camera until the Scan has been Stopped:

- **45° Auto Scan**
Camera pans back and forth 22.5° either side of the centre point (the position the camera is facing when the scan is activated).
- **90° Auto Scan**
Camera pans back and forth 45° either side of the centre point (the position the camera is facing when the scan is activated).
- **180° Auto Scan**
Camera pans back and forth 90° either side of the centre point (the position the camera is facing when the scan is activated).
- **360° Auto Scan**
Camera pans continuously through 360°, pausing every 108°.



There are three speed controls for each Scan. Slow, Medium and Fast.

A command is also available to ‘Re-Centre’ the scan. This can be found in the command list.

PRESET

From the MENU screen select the PRESET option. You will now be presented with a list of presets 1~8. For presets 9~16 nudge the joystick right. Select the desired preset and the camera will move at full speed to the position stored in memory. If there is no position stored in memory the camera will not respond. To return to the Home screen nudge the joystick up.

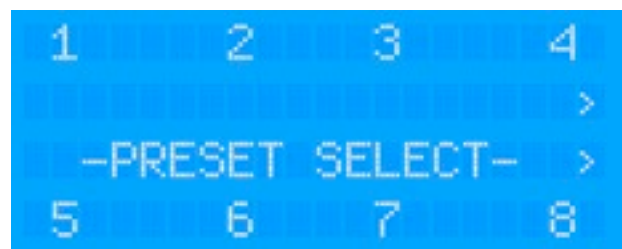

Presets can be stored from the SET menu (see below...)

FEATURES (FEAT)

The features menu should only be used on initial installation and is used to determine which controls are displayed. This will be factory set so you shouldn't need to change settings, but an explanation of the current features is listed below:



Payload Select (PAYL)

Determines whether the camera is single payload (IRIS290 / IRIS390) or dual payload (295 / 395) in order to display the appropriate controls.

GYRO

Determines whether the camera features Gyro stabilization in order to display the gyro specific controls.

To select any of the features above, toggle the keys until the appropriate value is shown.

Incorrectly setting these features will merely display functions on the controller that will have no effect.

SET MENU

From the SET menu, user presets and a home position can be stored and the camera can be sent into Standby Mode and be told to Wake up (Power Off/On). You can also set the camera speed and re-calibrate the thermal camera image (NUC).

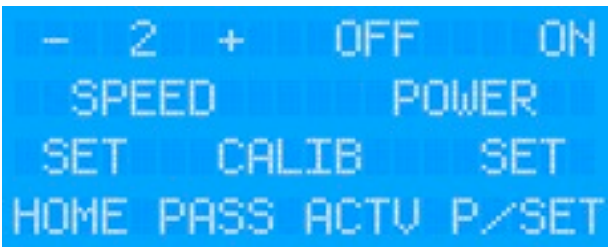

SPEED

Sets the camera control speed from 1 (slowest) to 3 (fastest).

Standby / Power Mode

From the SET menu, select POWER OFF to send the camera into Standby Mode. This will switch off the video feed and tilt the camera down so that the lens windows look into the housing cradle in order to protect the front face of the camera. To reawaken the camera, select the POWER ON key. This switches on the video and sends the camera to the Home position.

SET HOME

Sets the cameras home position. Move the camera to your desired position (usually looking straight forward) and press SET HOME. The camera can then be sent to the HOME position from the main Menu.

Camera Calibration

Although the thermal camera core automatically calibrates itself every couple of minutes, from time to time, especially in hot temperatures or in conditions of low thermal contrast it may be desirable or necessary to perform a manual calibration.

There are two levels of manual calibration available, called Passive or Active:

Passive:

Also referred to as NUC'ing (pronounced nuking), this is the standard method of calibration. Usually required in low thermal contrast conditions.

Active:

Active calibration can be used to improve the image if the camera temperature is high. Once selected, the camera will tilt down into it's standby position and operate it's shutter. This calibrates the thermal sensor to a 'flat' external image. Once the shutter has operated the camera will tilt back up to it's previous tilt position.

To calibrate the camera select the desired function (PASS or ACTV) from the SET menu.

User Presets

The camera has a built in memory that can be used to store up to 100 user 'preset' positions. A preset allows you to move the camera to a favorite or important position and learn that position so that the camera can be instructed to move at top speed to that position at the touch of a button. For example, you may want to point the camera so that it's facing directly aft so you can take a look at what's coming up behind you. By saving this position as a Preset, you can send the camera back to this position immediately by recalling the preset. Presets can also be used to form 'Tours', where the camera can be instructed to step through each preset within the Tour in sequence with a pre-determined dwell time between each position.

User presets are numbered 100-199. Usually the controller you are using will have the ability to SET a Preset to learn the position and then CALL a Preset to send the camera to that position. This will depend on the model of controller you are using. Consult the user guide of your controller for details. The IRIS595 controller allows you to set and recall 16 presets as described below:

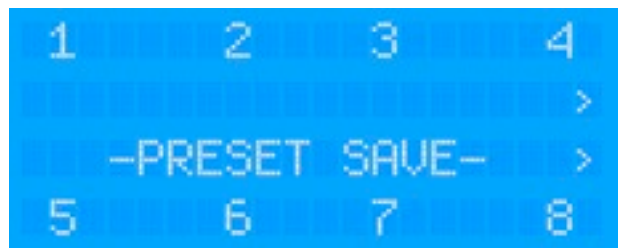

Set Presets

To set a user preset, first move the camera to the desired position. Next, from the SET menu select PRESET. A list of presets labelled 1~8 will be presented. For presets 9~16, nudge the joystick right. Select the preset number you wish to store. Your preset will now be saved in that memory position and you will be exited back to the Home screen.

Call Presets

From the MENU screen select the PRESET option. You will now be presented with a list of presets 1~8. For presets 9~16 nudge the joystick right. Select the desired preset and the camera will move at full speed to the position stored in memory. If there is no position stored in memory the camera will not respond. To return to the Home screen nudge the joystick up.

System Presets

Certain functions of the camera that are not defined by the Pelco-D Protocol are called by using Presets. A list of System Presets can be obtained by contacting Iris.

Camera Calibration

Although the thermal camera core automatically calibrates itself every couple of minutes, from time to time, especially in hot temperatures or in conditions of low thermal contrast it may be desirable or necessary to perform a manual calibration.

There are two levels of manual calibration available, called Passive or Active:

Passive:

Also referred to as NUC'ing (pronounced nuking), this is the standard method of calibration. Usually required in low thermal contrast conditions.

Active:

Active calibration can be used to improve the image if the camera temperature is high. Once selected, the camera will tilt down into its standby position and operate its shutter. This calibrates the thermal sensor to a 'flat' external image. Once the shutter has operated the camera will tilt back up to its previous tilt position.

To calibrate the camera select the desired function (PASS or ACTV) from the SET menu.

10.01 Notes

Colour Palettes

595 buttons call the following Palettes

Hot	Palette 5	PS:208/212	(Black Red / Red Hot)
Blue	Palette 2	PS:205/206	(Blue Green Red / Rainbow 1)
Warm	Palette 1	PS:203/204	(Blue Red Yellow / Purple Red Yellow)
Grey	Palette 0	PS:201/202	(White Hot / Black Hot)
Mix	Palette 4	PS:209/211	(Black Green Red / Mixed)
R.Bow	Palette 3	PS:207/210	(Rainbow 2 / Black Green Red-Pink)

Colour palettes have been grouped to provide the most logical pairing.

10.01 Notes (Continued...)

Iris Innovations Limited (UK)

Unit 15 Fareham Innovation Centre
Meteor Way, Lee on Solent. Hampshire PO13 9FU
United Kingdom
Tel: +44(0)2392 556509
email: info@boat-cameras.com
web: www.boat-cameras.com

Iris Innovations Limited (USA)

2821 SW 23rd Terrace, Unit 5
Fort Lauderdale, Florida 33312
United States of America
Tel: +1 (954) 533 9381
email: info@boat-cameras.com
web: www.boat-cameras.com



©2018 Iris Innovations Limited. All information correct at time of going to press.
Specifications are subject to change without prior notice. E&OE

v3.00 04-06-18